

OPERA IV

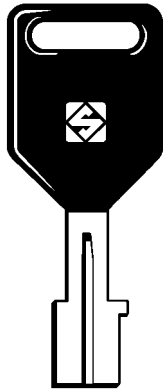

PER:
FOR:

BETA (I)



BE2P

OPTIONAL

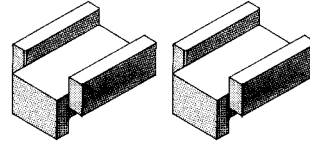



D705719ZB

*Adaptors for BE2P keys
Adattatori per chiavi BE2P
Adapters für BE2P Schlüssel
Adaptateurs pour clés BE2P
Adaptadores para llaves BE2P*

PER:
FOR:

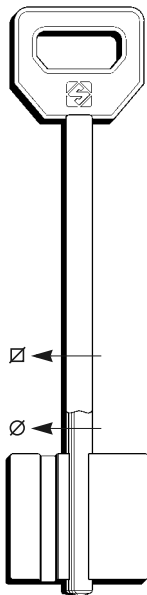
FIAM (I)



5FI21

OPTIONAL

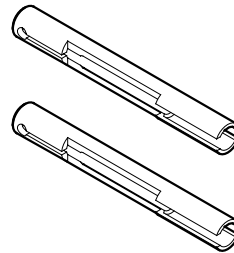

D722498ZB

*Adaptors for FIAM keys
Set adattatori per chiavi FIAM
Adapters für FIAM Schlüssel
Adaptateurs pour clés FIAM
Adaptadores para llaves FIAM*



OPERA IV



PER:
FOR:

FIAM (I)

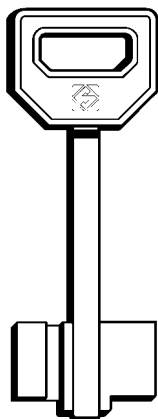

5FI5
5FI7
5FI9

OPTIONAL

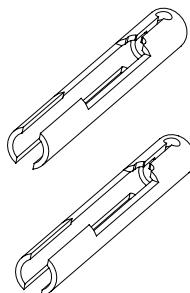

D727165ZB

Adaptors for FIAM keys
Set adattatori per chiavi FIAM
Adapters für FIAM Schlüssel
Adaptateurs pour clés FIAM
Adaptadores para llaves FIAM

PER:
FOR:

FORD (EU + USA)

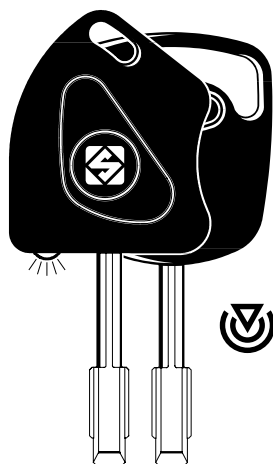

FO21T3L FO21T3
FO21PL



FO21P FO21AP

TIBBE (D)
VALEO (F)

IMPORTANT!

Key blank to be applied to the original remote control (the remote control includes the transponder chip)

OPTIONAL

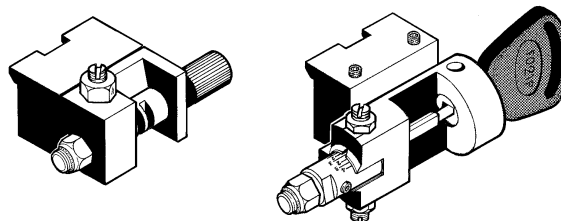

D705042ZB

Code attachment
Dispositivo a codice
Code-Vorrichtung
Dispositif à code
Dispositivo a código



OPERA IV



PER:
FOR:

GB2 (I)

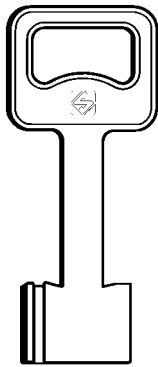

GBZ1

OPTIONAL



D705922ZB

*Stop bar for GBZ1 keys
Barretta-fermo per chiavi GBZ1
Anschlaglehre für GBZ1 Schlüssel
Barrette d'arrêt pour clés GBZ1
Tope para llaves GBZ1*

PER:
FOR:

MOTTURA (I)

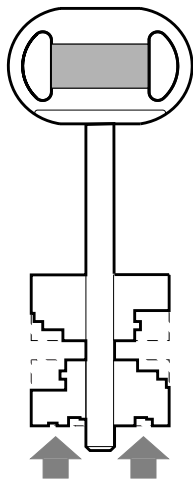

OPTIONAL

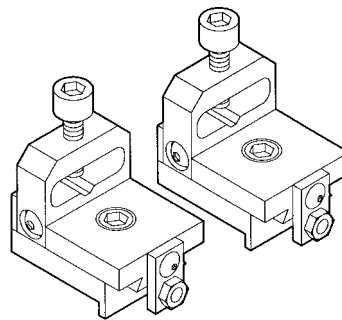

D713226ZB

*Device for pump keys with mixed cuts
Dispositivo per chiavi a cifratura miste
Vorrichtung für Pumpenschlüssel
Dispositif pour clés à pompe avec taillages diverses
Dispositivo para llaves a bomba con cifrados mistos*



ATTENTION: for repairs or replacement of parts for maintenance, the 'CE' mark is guaranteed only if original spare parts provided by the manufacturer are used.

ATTENZIONE: in caso di riparazioni o sostituzione di pezzi per manutenzione, la marcatura "CE" è garantita solo se vengono utilizzate parti di ricambio originali fornite dal costruttore.

ACHTUNG: bei Reparaturen oder Auswechseln von Teilen zur Instandhaltung wird die CE-Markierung nur bei Verwendung von vom Hersteller gelieferten Originalersatzteilen gewährleistet.

ATTENTION: si vous effectuez des réparations ou que vous remplacez des pièces pendant un entretien, le marquage "CE" n'est garanti que si vous utilisez des pièces de rechange originales fournies par le fabricant.

ATENCIÓN: en caso de reparaciones o sustituciones de las piezas por mantenimiento, se garantiza la marca "CE" sólo si se utilizan partes de repuesto originales suministradas por el constructor.



SILCA S.p.A.

Via Podgora, 20 (Z.I.) 31029 VITTORIO VENETO (TV)

Tel. 0438 9136 Fax 0438 913800

www.silca.it

Member of the Kaba Group

